



REQUEST FOR PROPOSAL:

Supply, Installation and Commissioning of Biogas Energy System for Onesua Presbyterian College

Background

In Vanuatu, rural households have limited access to modern cooking fuels and technologies. The reliance on biomass (fuelwood or firewood) for household thermal energy needs is raised in the 2007 National Agriculture Census, which reports that out of the 33,879 households surveyed, 95% (32,096) of these households were gathering fuel wood every day for domestic use as well selling it in markets.

Through the updated National Energy Roadmap (NERM), the Government of Vanuatu wants to reinforce that modern-cooking fuels and technologies (including biogas generation at household and institutional scale) are an important form of energy use in Vanuatu, and an area where improvements are possible.

Agriculture is a significant part of Vanuatu's economy. Subsistence agriculture is the dominant source of livelihood for 80% of the country, whom live in rural areas. Although Vanuatu has good resources and ideal climatic conditions for generation of biogas, the technology has not really taken off in the country.

In light of the above, the Department of Energy (DoE) conducted a feasibility study to determine the availability of biomass resource at Onesua Presbyterian College. The college has been chosen as a pilot site for a biogas system, and the feasibility study calculated the biogas potential at the school and provided DoE with technical system design to help DoE construct a biogas system at the school.

The biogas system will be constructed with project funding under the EU-GIZ Adapting to Climate Change and Sustainable Energy (ACSE) project. This is the first major biogas installation in Vanuatu, and it will provide DoE with invaluable experience to help realise the potential of this resource. Hence, this document invites suitable contractors to submit their proposal to manufacture and assemble the biogas digester, install it on site, pilot the plant and facilitate training to beneficiaries.

Deliverables

- i) Completed construction of the Biogas Digester;
- ii) Installation of the Digester along with all other pipe works;
- iii) Inspections checked and approved.
- iv) Piloting plant for 2 months.
- v) Facilitate Training to beneficiaries.
- vi) Commissioning.

Evaluation Criteria

The following evaluation criteria and the weightings for the evaluation will be applied when selecting the successful Contractor:

- i) Conformity to the Terms of Reference; (40%)
- ii) Qualifications/requirements, skills and experience; (15%)
- iii) Total number of working days to carry out the required tasks; (5%)
- iv) Total quoted price (40%)

Qualifications, Skills and Experience

The contractor is expected to satisfy most, or all of the following qualifications, skills and experience:

- i) Must have a valid business licence;
- ii) Metal works trade certificate or similar;
- iii) Welding trade certificate or similar;
- iv) Building Construction or Carpentry qualifications or higher;
- v) Must have at least 5 years of experience in the building industry;
- vi) Able to read and understand technical drawings;
- vii) At least 2 years of experience in biogas plant installation, or in the area of plumbing and gas-fitting;
- viii) Technical expertise in piloting biogas plant.
- ix) Experience in facilitating training.
- x) Experience in working with a variety of stakeholders, including Government agencies, NGOs, civil society, communities.

Things to Submit

- i) Cover letter & CV/Capability Statement;
- ii) Required Business Licences and Certificates to satisfy the Qualifications, Skills and Experience as detailed above;
- iii) Proposed plan and Gantt chart of delivering the scope of work in the Terms of Reference;
- iv) Proposed material quantity and costs as per **Appendix 3**;
- v) Labour costs and all other associated costs

Contact Person

Submission of proposal, including contact details of the person or company must be submitted on or before Close of Business (COB) of 13th of October 2017.

Japeth Jacob
ACSE Project Manager
Department of Energy
PMB 9067
Phone: 25201
Port Vila

Vanuatu

Attention: Japeth Jacob

Email: jjapeth@vanuatu.gov.vu

Submission sent by post must be in a sealed envelope marked 'RFP Bio-Gas Onesua. Submissions will be also accepted by email. The Department of Energy reserves the right to reject submissions that arrive later than the above deadline.

Bidders may only submit one bid which cannot be modified.

TERMS OF REFERENCE

1) Background

The GIZ ACSE project is a technical assistance project which aims to pilot the use of biogas for cooking within Vanuatu.

2) Objectives

The objective of this assignment are;

- i) To manufacture and install the Digester at Onesua Presbyterian College as per **Appendix 1 to Appendix 3**; and
- ii) To connect all the necessary plumbing works to the crusher, digester and slurry tank, and to the kitchen stove,
- iii) Pilot the successful operation of the plant for 2 months,
- iv) Facilitate training to beneficiaries and
- v) Commission of the Biogas Plant.

3) Scope of Work

The key activities under the assignment include (but are not limited to):

TASK No.	Task Description
1. Manufacturing	<ul style="list-style-type: none">- Organise meetings with Project Team at DoE to clarify any details associated with biogas plant design, construction or pilot operation- Manufacture the Biogas anaerobic Digester according to the plant design;- Report to Project Manager
2. Transportation	<ul style="list-style-type: none">- Arrange for Transportation of material and equipment.- Transport digester, materials and equipment to the construction site.
3. Installation	<ul style="list-style-type: none">- Clear site for construction;- Build concrete platform to support the biogas plant;- Install Digester- Connect the crusher, digester, slurry tank and the Kitchen gas burner with appropriate piping and fittings.- Test product and check for faults;- Be available to pilot the operation of the plant in the first 2 months and report operation data- Obtain 2-month operation report approval from School and DoE
4. Training	<ul style="list-style-type: none">- Prepare training materials for biogas plant operation & maintenance and trouble shooting.- Liaise with Project Manager in facilitating training for operation, maintenance and troubleshooting to beneficiaries
5. Commissioning	<ul style="list-style-type: none">- Provide 2 months report on biogas plant operating condition.- Handing over to DoE.

4) Deliverables

- I. Completed construction of the Biogas Digester;
- II. Installation of the Digester along with all other pipe works;
- III. Inspections checked and approved
- IV. Piloting plant for 2 months.
- V. Facilitate Training to beneficiaries.
- VI. Commissioning of the Biogas Plant

5) Inputs

The Department of Energy (through the Project Manager with the assistance of the Project Team) will provide oversight and assistance to the consultant or contractor in the coordination and implementation of the assignment.

APPENDIX1: Proposed Design for Onesua Biogas Plant

A mild steel pre-fabricated biogas plant (see technical design section) is recommended for the Onesua College. It is estimated that the 100kg/day biogas plant will generate approximately 6-8 m³ of biogas on a daily basis. The biogas generated will be supplied to kitchen for meeting energy needs for cooking. The digester of 6 m³ capacity and designed for a hydraulic retention time of 30 days.

The biogas plant needs to be fed manually on a daily basis. The feed mixture includes all organic waste generated on the premises (100kg/day) which needs to be crushed in a crusher and mixed with 100 to 150 litres of water. Kitchen waste and cooked food does not require crushing. Some of the key requirements include:

- A concrete platform needs to be constructed as per the design drawing for the placement of the bio gas digester.
- Onesua college authorities need to ensure that the biogas plant is fed on a daily basis as per the checklist provided at the time of installation.
- The biogas plant must be fed with waste of specified quantity (100kg/day- of kitchen waste/dining waste/vegetable Waste/ cattle waste + cassava waste) daily, for the plant to function properly.
- Under feeding or lack of feeding/over feeding reduces biogas.
- Person (s) have to be duly appointed to feed the biogas plant regularly and person shall be held responsible for running the biogas plant post O & M training.
- Water tank and supply pipeline to the crusher and digester to be provided; crusher to be powered from onsite generator.
- Rain water harvesting can be explored using the roof surface at Onesua college kitchen and appropriate storage facility for the water to be used during biogas digester operation.

A flow diagram for the working of the Onesua 100kg/day biogas plant is provided below:

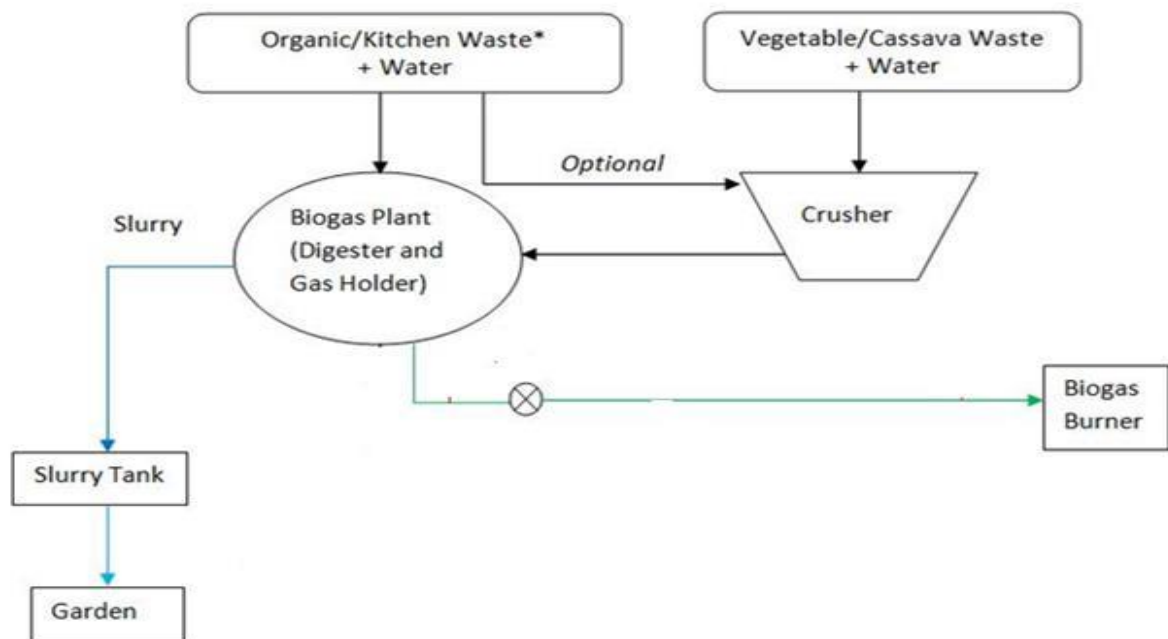

The typical layout and section of the 100 kg/day biogas plant for the Onesua College:

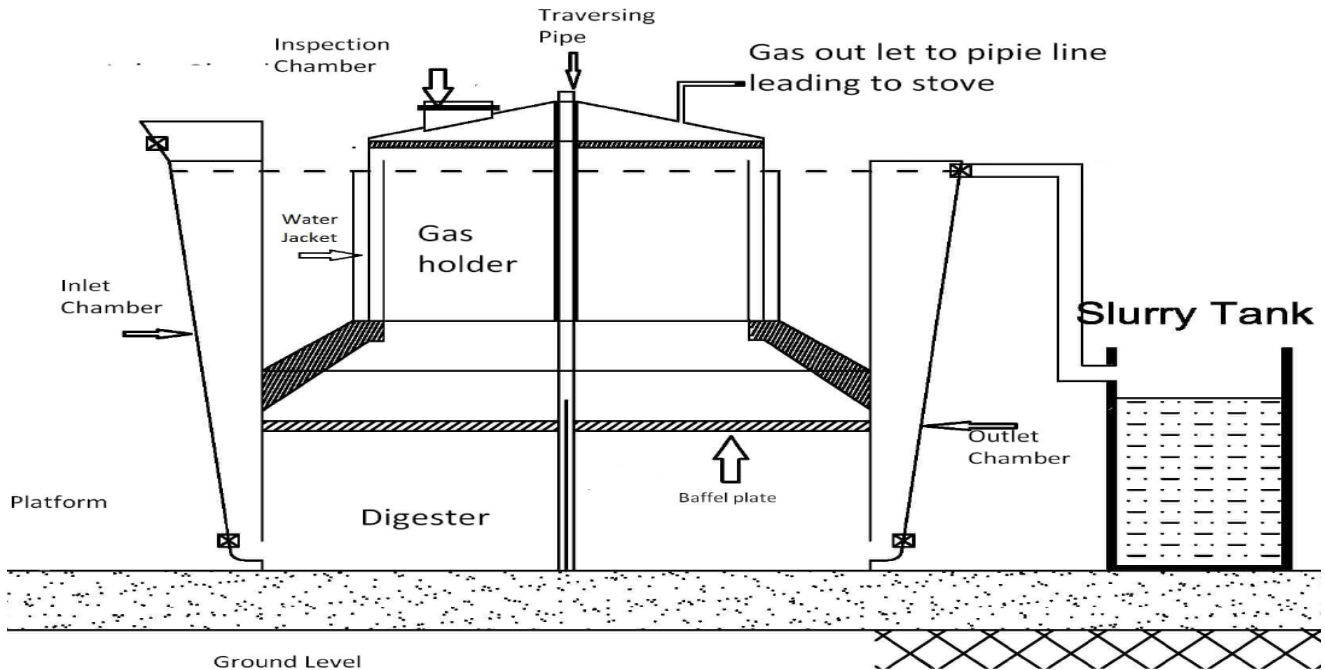

The key functions for each of the component.

Sl	Component	Functions
1	Digester with water jacket	A cylindrical structure to facilitate anaerobic digestion, Water jacket is constructed at the top of main digester above ground level and it will be filled with water and is indeed a peculiar feature which separates the proposed plant from the conventional biogas plants where in the Gas holder rests on slurry, Water jacket helps in maintaining hygienic conditions around the plant and houses the gas holder with immersion in water
2	Gas holder	It is a mild steel structure to store biogas generated in the main digester it is mounted on the top of main digester between the water jack walls. It will be immersed in water
3	Inlet Chamber	It is a small rectangular with Hopper prior to digester
4	Outlet Chamber	It is a small rectangular chamber after main digester, it is connected with main digester through outlet pipe
5	Slurry tank	It is a tank for storage of slurry (liquid) which is obtained after digestion. Every day 150L to 200L of slurry is generated. The tank will be sized to store slurry for five days at least

6	Baffle Plate	Baffle plate acts as a stationary barrier within the digester ensuring proper mixing of the feedstock with the slurry avoiding stratification (separating into layers).
7	PVC Pipes	PVC pipes of different size are required for intermediate connections with in the plant
8	Copper pipe line	Copper Pipe line is required for transmission of biogas
9	Moisture Trap Systems	Moisture Traps are provided at several points from the biogas generation point to biogas utilisation point. These systems are required to remove moisture from biogas and help in free flow of biogas
10	Crusher	It consists of a motor coupled with chopper plate to cut fibrous material without clogging. It is used for crushing the raw waste mixture (raw waste + water) to prepare uniform flow-able slurry of biodegradable waste. Crushing serves the following <ul style="list-style-type: none"> ➤ Preparation of feedstock with uniform characteristics ➤ Preparation of feedstock with desired solids concentration (23 to 25%)

The table below contains a summary of the project; the system required, the issues to be addressed; the requirements of the biogas plant and the expected benefits and outcomes of the project.

Fields	Brief Details
Project	Establishing a 100kg per day for Organic waste Biogas Plant at Onesua College
System	100 kg per day organic waste biogas plant estimated to generate 6 – 8 m ³ /day of Biogas
Issue(s) to be addressed	Solid Waste Management, Waste to Energy
Requirements	<ul style="list-style-type: none"> ❖ 100kg of segregated biodegradable waste per day (Organic waste/vegetable waste /kitchen waste/dining waste/cassava waste / cattle waste ❖ 100 to 150 litres of water per day ❖ Regular water supply near the plant and water storage tank ❖ Electric power supply at the switch board for crushing of waste (1 Hour crushing daily) ❖ A concrete platform 3.90m x 3.90m to support the biogas plant ❖ Plant Area of 25m² free from encroachments

Benefits/Outcomes expected	<ul style="list-style-type: none">❖ Biogas:-to be used for cooking.❖ Savings:-Cost, time and intangible efforts to process and/or dispose the waste is saved❖ Treatment:-Waste is treated effectively❖ Slurry:-in liquid state can be directly irrigated or dried to obtain compost/mixed with leafy litter and used as composted
----------------------------	--

APPENDIX 2: Technical Specification

Detailed Design Drawings of the Mild Steel pre-fabricated 100kg/day Biogas Plant for Onesua College.

Digester Design Specifications

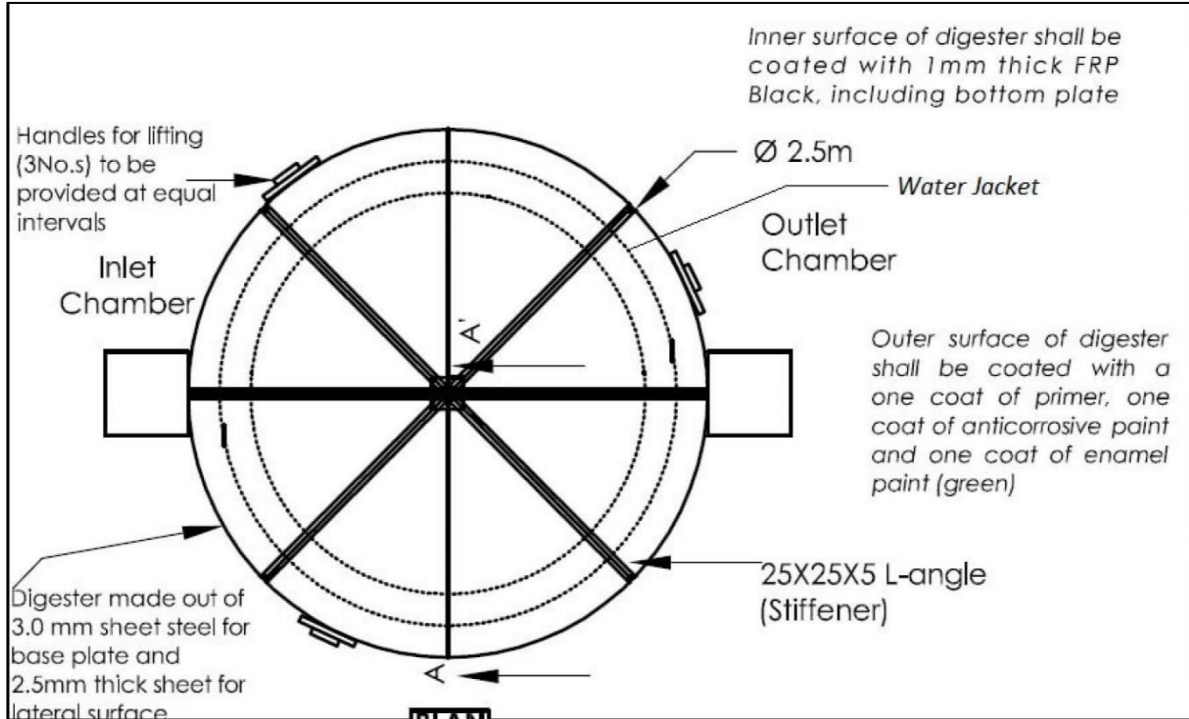

Digester Plan

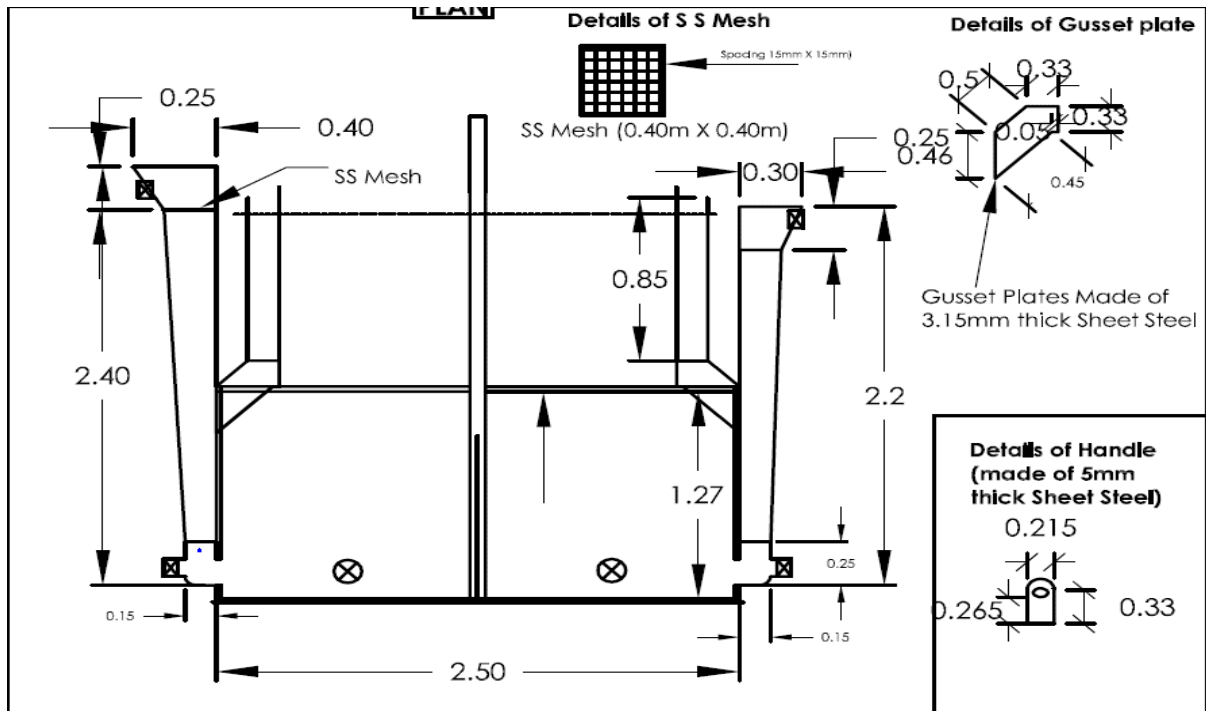

Digester Section View

Gas Holder Design Specifications

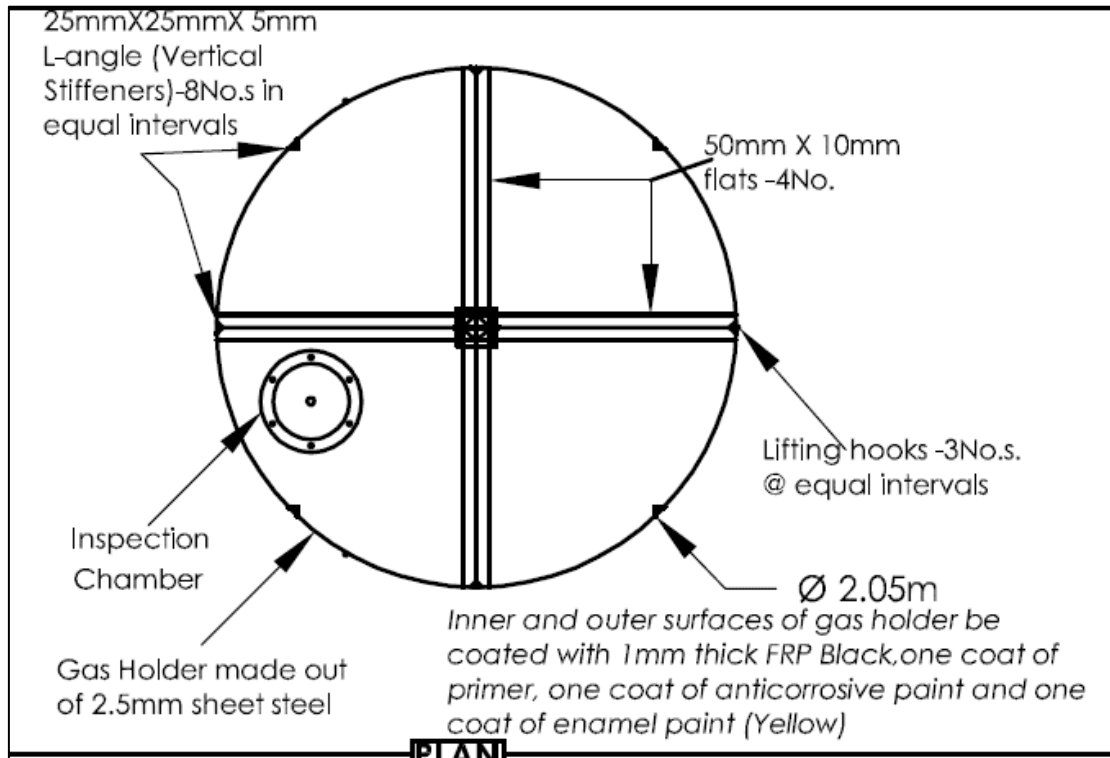

Plan View Gas Holder

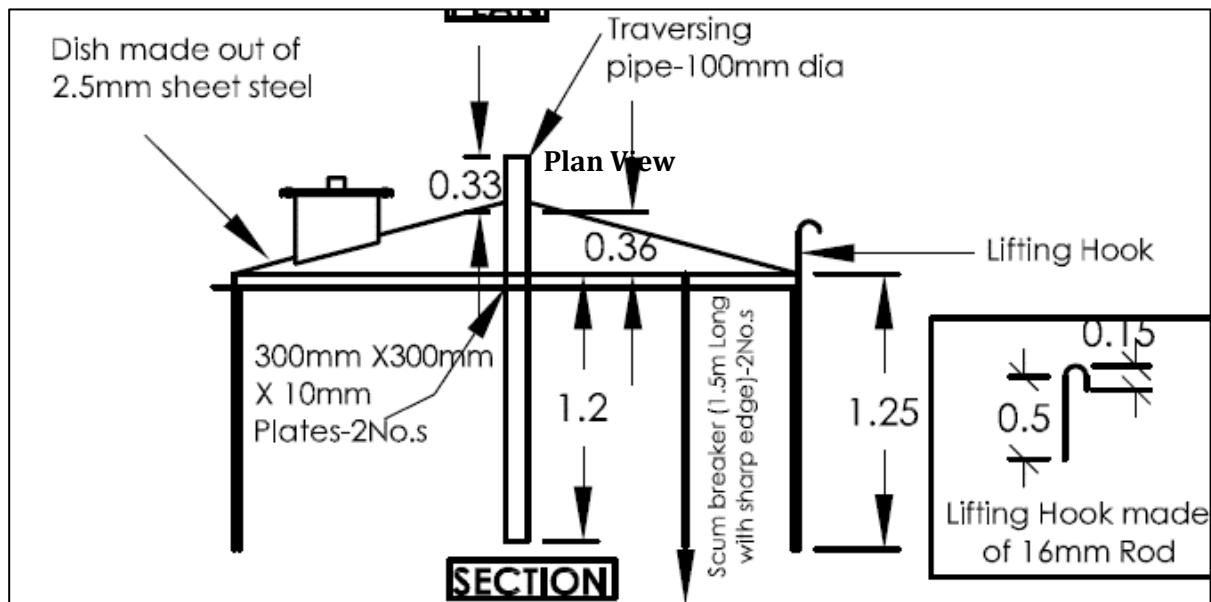

Section View Gas Holder

Inlet Chamber, Mounting and Inlet Pipe

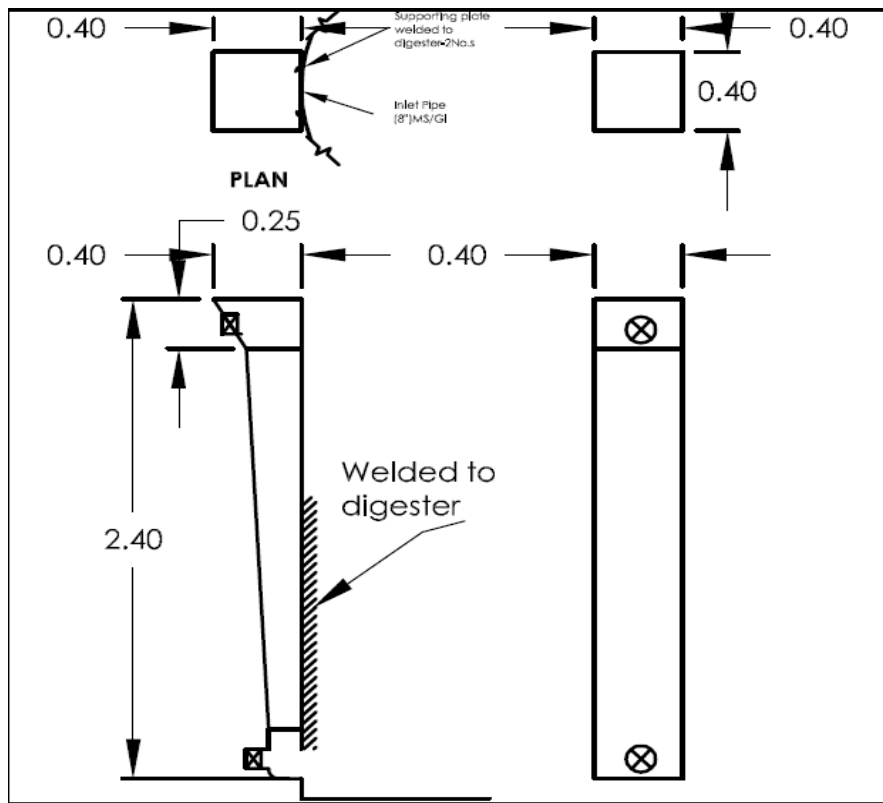

Outlet Chamber, Mounting and Outlet Pipe

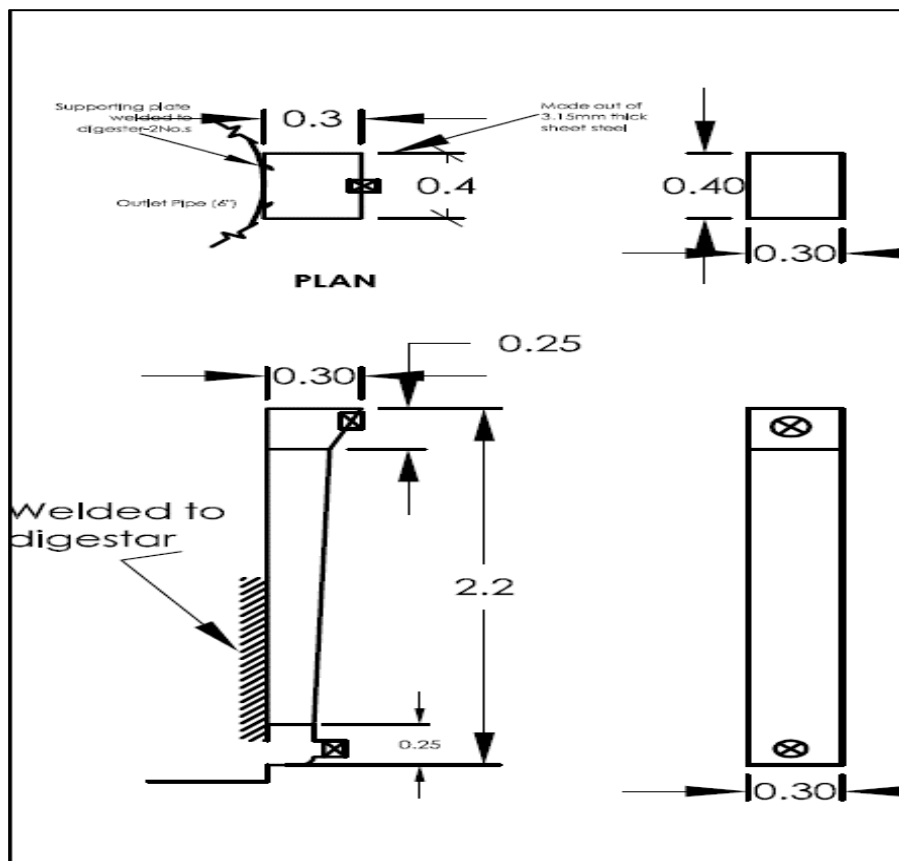

Inspection Chamber

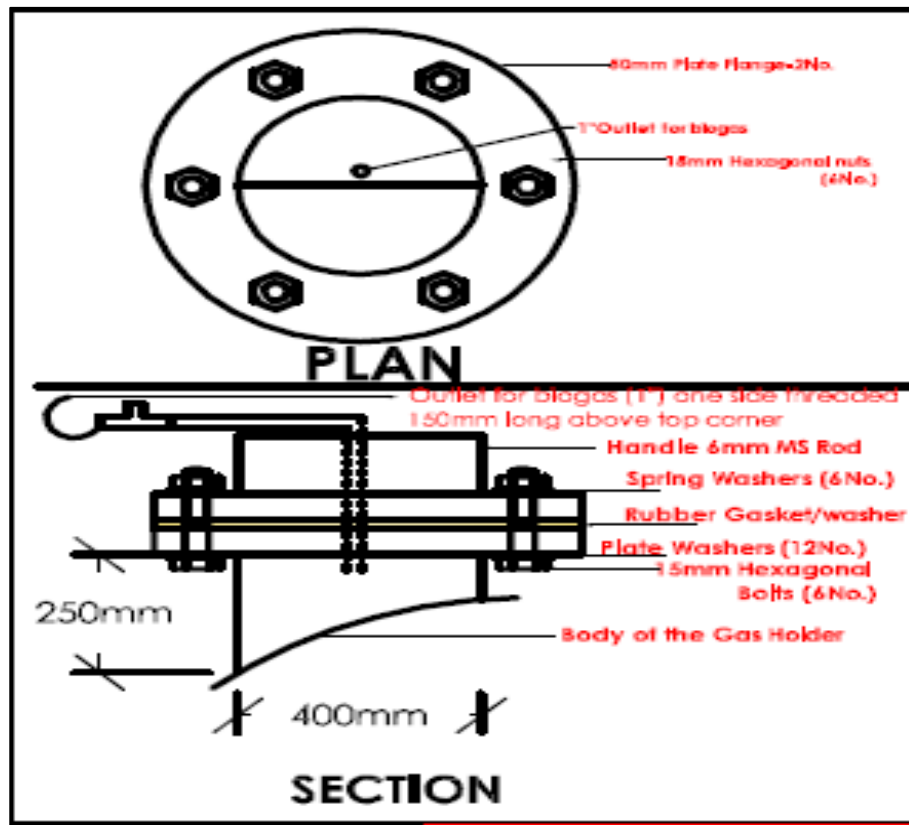

Edge View of Baffle Plates (2 nos needed)

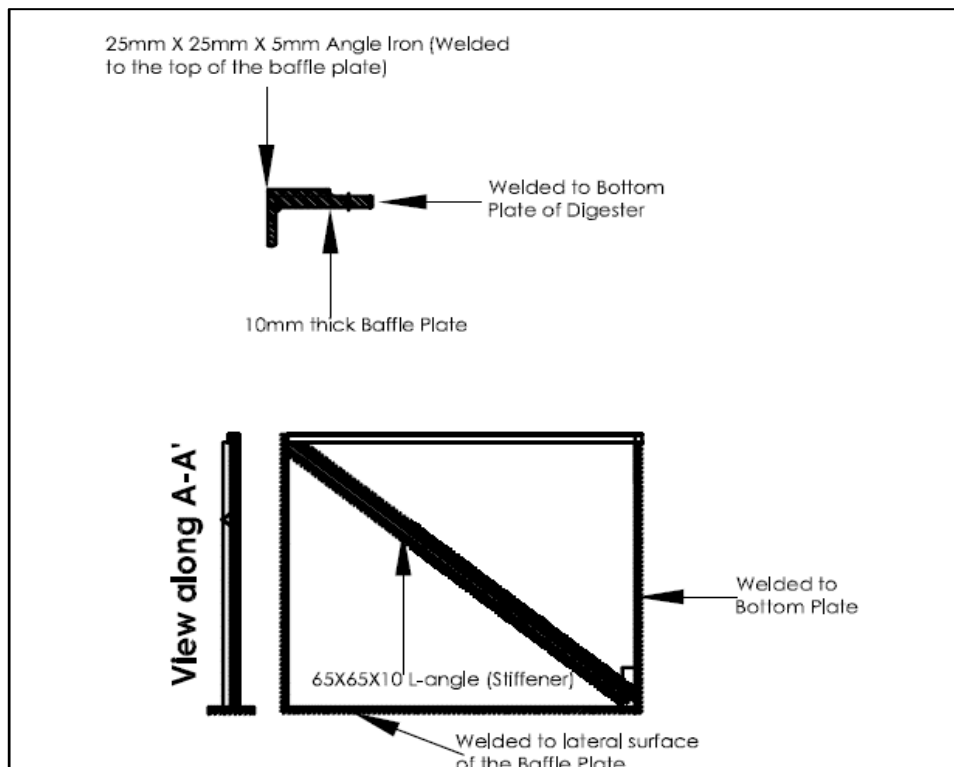

Details for Welding 50mm X 5mm flats (4 nos)

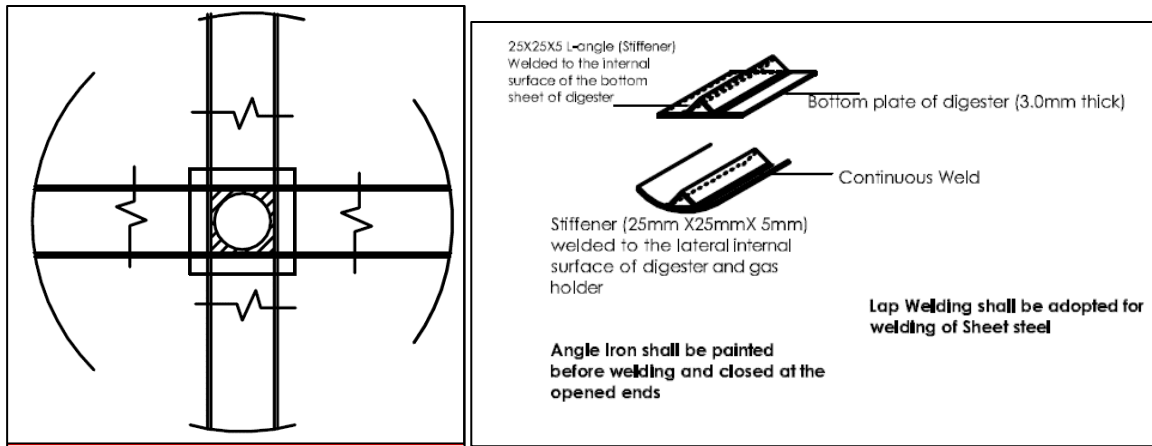

Layout for Concrete Platform for 100kg/day Biogas Plant

Drawn to Scale and all dimensions are in meters.

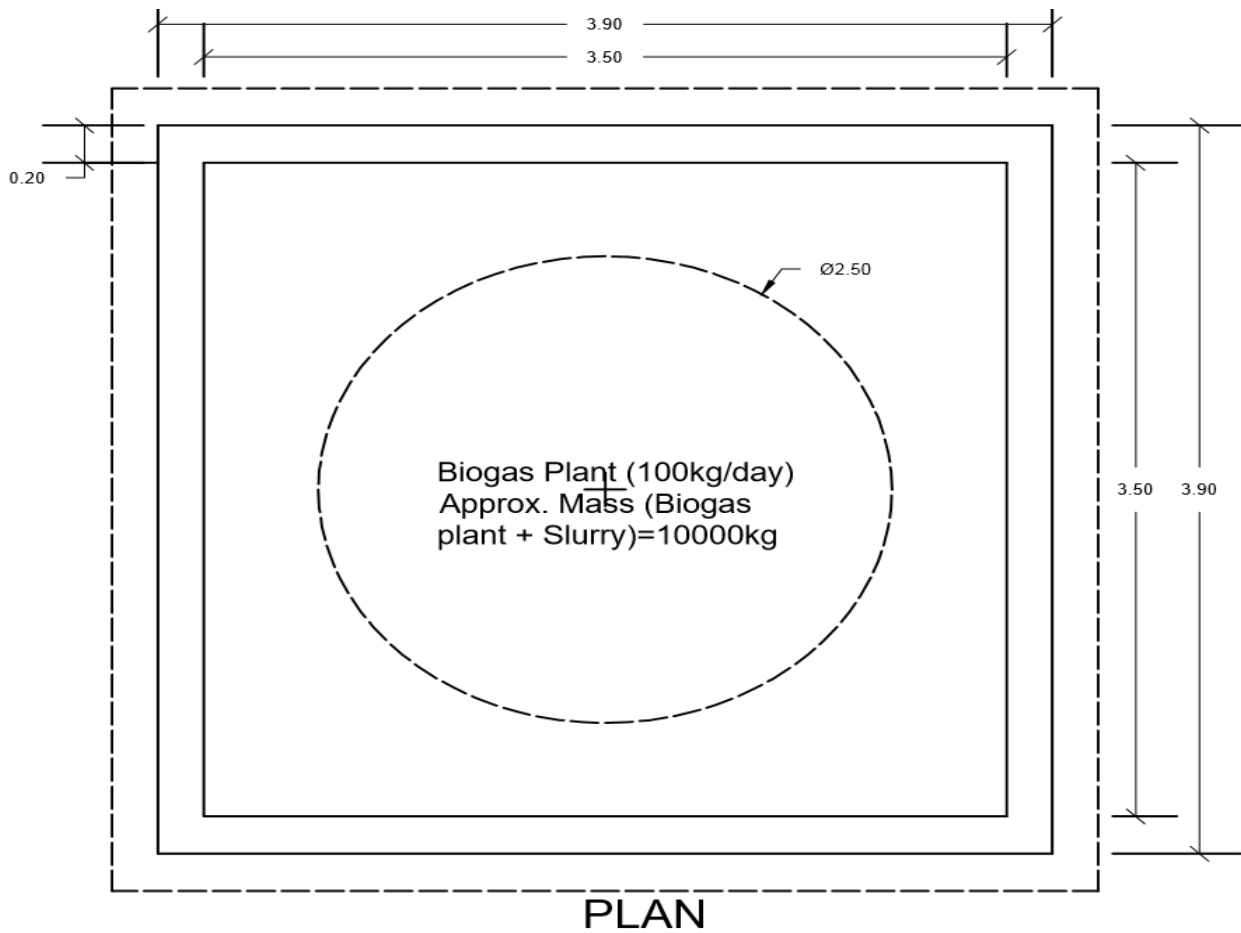

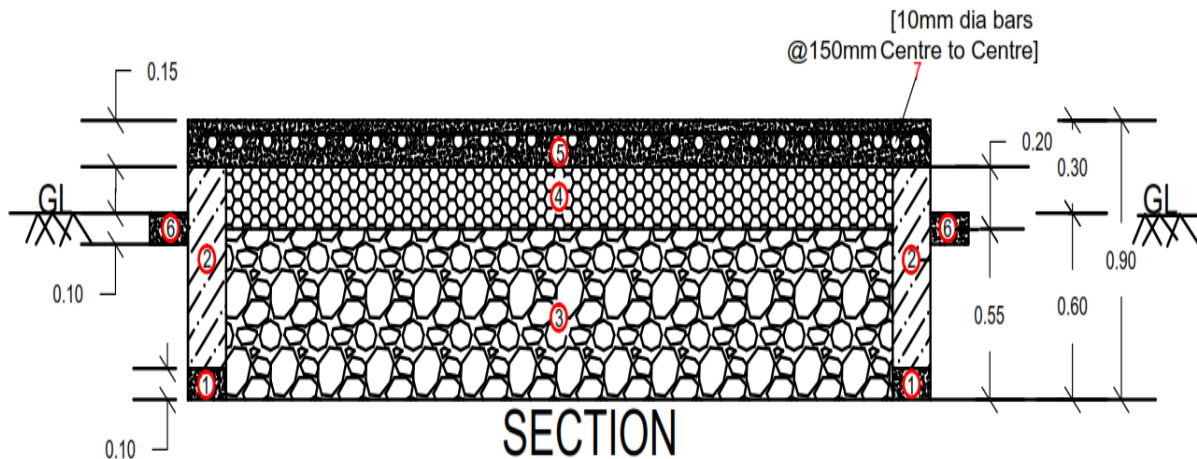

Sl No.	Specifications of the platform
1	M10 Plain Cement Concrete (PCC 1:3:6): Laying in position plain cement concrete of mix M10 with Ordinary Portland Cement @220kgs/Cu.m of concrete, with 40mm and down size graded granite metal coarse aggregates @0.878cum/ Cu.m of concrete and fine aggregates (Sand) @ 0.459cum/Cu.m of Concrete-10cm thick as per the drawing
2	Size Stone Masonry: Constructing granite/trap/ size stone masonry in foundation with cement mortar 1:6, stone hammered, dressed in courses not less than 20 cm high, as per the drawing
3	Soling with coarse aggregates: Filling in foundation with granite/ trap broken metal 200 mm and down size, with sand packing and ramming as per the drawing
4	Soling with coarse aggregates: Filling in foundation with granite/ trap broken metal 100 mm and down size, with sand packing and ramming as per the drawing
5	Reinforced Cement Concrete (RCC) M25: Laying in position Reinforced Cement Concrete of design mix M 25 with Ordinary Portland Cement @ 340kgs/Cu.m of concrete, with 20mm and down size grade granite metal coarse aggregates @0.70cu.m/Cu.m of concrete and fine aggregates @ 0.47Cu.m/Cu.m of concrete with super plasticiser @ 3L confirming to IS 9103-1999 re affirmed-2008, as per the drawing
6	M15 Plain Cement Concrete (PCC 1:2:4) Laying in position plain cement concrete of mix M15 with Ordinary Portland Cement @240kgs/Cu.m of concrete, with 40mm and down size graded granite metal coarse aggregates @0.892cum/ Cu.m of concrete and fine aggregates (Sand) @ 0.465cum/Cu.m of Concrete- as per the drawing
7	10 mm Steel Bars for Reinforcement Providing Thermo Mechanically Treated (TMT) Steel reinforcement with 10mm steel bars for RCC Works, as per the drawing

APPENDIX 3: The detailed components and material take-off list

CORE COMPONENTS and scope of work

Item with specification	Qty	Unit
<p>1. Biogas Plant</p> <p>a) Main Digester: Mild steel (MS) Main Digester of capacity 6 m³ with water jacket lateral surface fabricated out of 2.5mm thick and base with 3.0 mm Hot Rolled Mild Steel Sheets, with necessary circumferential, tangential, radial, lateral support frames made of M S Angle Iron (L-angle) 25mm X 25mm X 5mm, MS Flats, Flanges, Bolts, Nuts, Guide Pipe inclusive of one primer coat, inner surface of digester and water jacket with 1.0mm FRP Coat and all outer surface with two coats of black japan paint or Duco paint.</p> <p>b) Gas Holder: Mild Steel Gas Holder of volume 4 m³, fabricated out of 2.5mm thick Hot Rolled Mild Steel Sheets, with necessary circumferential, tangential, radial, lateral support frames made of M S Angle Iron (L-angle) 25mm X 25mm X 5mm, MS Flats, Flanges, Bolts, Nuts, Guide Pipe etc. complete inclusive of one primer coat, inner surface of digester and water jacket with 1.0mm FRP Coat on both inner and outer surfaces</p> <p style="text-align: center;">10 mm</p>	1	No.
<p>2. Pipe line for Slurry: PVC Pipeline of diameter 4" (10kg/Sqm) with necessary fixtures like Tee ,collar , butterfly valves and bend for flow of slurry from Outlet of Main Digester to Slurry Tank capacity of 1000L (20 mts)</p>	1	Set
<p>3. Gas flow pipe line: Copper pipe line (3/4)" of 10m length. + connections</p>	1	No.
<p>4. Gasmeter : Gasmeter for measuring the gas, to withstand a discharge of 4Cum/hour and pressure of 200millibar, inclusive of moisture trap to collect the moisture and necessary fittings</p>	1	No.
<p>5. Slurry Tank: PVC 3 layered tank for storage of slurry (1000L capacity)</p>	1	No.
<p>6. Transportation: Transportation of Biogas plant from manufacturing premises to site</p>		As required
<p>7. Erection of Biogas plant at Site: Erecting Gas holder and Main Digester in position on the platform with proper vertical and horizontal using crane.</p>	1	No.
<p>8. Supervision/Inspection of Electromechanical Accessories at Manufacturer's Premises</p>	1	Job
<p>9. Field Visit: Monitoring /Supervision/Inspection at Installation site (for Plumbing works, inoculation of microbial culture, Electrical works, civil works)</p>	1	Job

10. Running the plant i.e Supervision, guidance and maintenance, monitoring of biogas plant for two months	2	Months
11. Crusher for crushing organic waste at a rate of 100kg per hour (Grinding Chamber: FG 200 / GG 200, Hopper: FG 200 / GG 200, Teeth Ring: AISI: SS 440 C, Impeller: AISI : SS 440 C, Cutter Blades, Hardened Chrome Steel, Shaft: AISI : SS 431, Mechanical seal: Carbon \ Ceramic (this is required for input of raw Vegetable waste!)	1	No
12. Electrical Connections for crusher : Electric Panel Board (IP 65) with DOL Starter, MCB, RCCB, Earth leakage Relay, Wiring from Electric panel board to electromechanical accessories switches and Earthing (this is required if crusher is installed & raw Vegetable waste has to be fed!)	1	SET
13. MS stand/enclosure for the Biogas plant – located in between platform and the Prefabricated plat	1	No



Representative picture of a typical 100kg/day pre-fabricated mild steel biogas plant

APPENDIX 4: Installation Site (Onesua Presbyterian College)

Space for Installing the Biogas Plant.



Kitchen Space



